

DF | DOUBLE PRELOADED NUT TYPE DIN 69051/5 FOR GROUND SCREWS

3

DIFFERENT PITCH AND DIMENSIONS ARE AVAILABLE UPON REQUEST. DIMENSIONS IN INCHES ARE ALSO AVAILABLE
*NON-NORMALIZED TYPES / **BALLSCREWS 2 PRINCIPLES

TYPE	d _o	P _h	D _w	N	D	D ₁	D ₂	D ₃	L	L ₁	L ₂	L ₃	L ₄	L ₅	H	C _o	C _a	R _s
DF5010-3				3					148							10911	6049	126
DF5010-4	50	10	6,35	4	75	93	110	11	168	7	16	10	85	8	2	13456	7460	156
DF5010-5				5					188							15893	8812	184
DF5010-6				6					208							18180	10081	210
DF5012-3				3					161							11730	7072	124
DF5012-4	50*	12	7,144	4	75	93	110	11	185	7	16	16	85	8	2	14467	8722	154
DF5012-5				5					209							17086	10303	182
DF5012-6				6					233							19545	11786	208
DF5016-3				3					199							11730	7073	124
DF5016-4	50	16	7,144	4	75	93	110	11	231	7	16	25	85	8	2	14467	8723	154
DF5016-5				5					263							17086	10302	182
DF5020-3	50*	20	6,35	3	75	93	110	11	228	7	16	25	85	8	2	10911	6049	126
DF5020-4				4					268							13456	7460	156
DF5020-3-B	50	20	9,525	3	75	93	110	11	228	7	16	25	85	8	2	15068	10147	118
DF5020-4-B				4					268							18583	12514	146
DF5030-3**	50	30	7,144	3	75	93	110	11	212	7	16	25	85	8	2	11730	6400	124
DF5050-2	50*	50	6,35	2	80	98	115	11	270	7	16	45	90	8	2	8263	4581	96
DF6305-3				3					95							8149	2166	140
DF6305-4	63	5	3,175	4	90	108	125	11	105	7	18	10	95	9	2	10050	2671	172
DF6305-5				5					115							11870	3155	204
DF6305-6				6					125							13578	3609	234
DF6310-3				3					150							14410	6471	152
DF6310-4	63	10	6,35	4	90	108	125	11	170	7	18	16	95	9	2	17772	7981	188
DF6310-5				5					190							20990	9427	222
DF6310-6				6					210							24011	10784	254
DF6312-3				3					168							16119	7561	154
DF6312-4	63*	12	7,144	4	90	108	125	11	192	7	18	16	95	9		19879	9325	190
DF6312-5				5					216							23479	11015	224
DF6312-6				6					240							26858	12601	258
DF6316-3				3					205							22276	10836	152
DF6316-4	63	16	9,525	4	95	115	135	13,5	245	9	20	25	100	10	2	27473	13364	188
DF6316-5				5					277							32448	15784	222
DF6320-3				3					234							22248	10829	152
DF6320-4	63	20	9,525	4	95	115	135	13,5	274	9	20	25	100	10	2	27438	13355	188
DF6320-5				5					314							32407	15775	222
DF6330-3	63	30	9,525	3	95	115	135	13,5	298	9	20	25	100	10	2	22276	10836	152

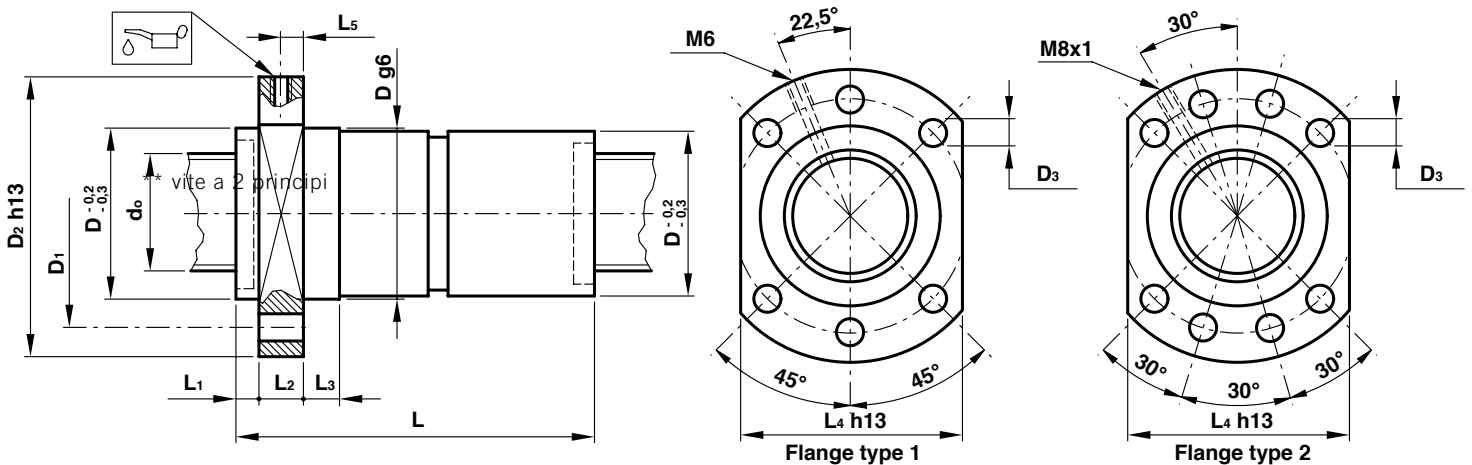

- N Nr of ball screw revolutions
- H Flange type
- d_o Major diameter (mm)
- P_h Pitch (mm)
- D_w Ball diameter (mm)
- C_o Static load capacity (daN)
- C_a Dynamic load capacity (daN)
- R_e Nut rigidity (daN/μm)

OFFICINA MECCANICA B.B.
WWW.OFFICINAMECCANICABB.COM

